



 **SANKYO AMERICA, INC.**

P.O. Box 4338 • 10655 St. Rt. 47 • Sidney, Ohio 45365 U.S.A.

Phone 937-498-4901 • Fax 937-498-9403

SANKYO LINEAR MOTION TYPE TORQUE LIMITER

THEORY OF OPERATION

Sankyo's LM Limiters are a compact solution for part handler protection against linear motion restrictions. The mechanism consists of a slide unit and ball & ball pocket arrangement.

FEATURES

1. Linear Overload Protection

The LM Limiter is the only torque limiter that protects against overloads in linear motions; particularly high-speed linear motions such as those performed by pick and place units (i.e. Sankyo's Parts Handler). The LM Limiter mounts easily on the output shaft of pick and place units and reciprocal moving members driven by air cylinders.

2. Accurate Operation

The power transmission mechanism used in the LM Limiter draws on Sankyo's vast experience and proven reliability with the ball & ball pocket mechanism (a mechanical power isolating system). All moving parts incorporate measures to minimize friction loss making the LM the most advanced linear torque limiter available today.

3. Tripping Force Adjustment Mechanism

The amount of torque required to trip the limiter depends on the geometrical configuration of the ball & ball pocket, and the compression of the spring. Regulating the amount of transmission torque requires only a simple pressure nut adjustment to change the compression of the spring.

4. Overload Detection

When an overload occurs, the pressure dislodges the ball from its ball pocket thereby freeing the slide mechanism and effectively disconnecting the transmission of power. The displacement of the ball pushes the overload detection pin out by approximately 2 mm. This pin can be used to activate an electrical sensor, such as a proximity switch or micro photo-sensor, for use in the stop control of the machinery.

5. Precise Resetting Accuracy

After tripping, the limiter will return to within ± 0.03 mm of its original position making it highly suitable for high-speed reciprocal motions. To reset the limiter, remove the cause of the overload and slide the follower (slide unit) back to its original position.

6. Compact Design

The LM Limiter uses lightweight parts wherever possible with key operating components integrated into a compact design. Many applications will benefit from the LM Limiter, particularly applications that call for high-speed reciprocating motions.

MODEL SELECTION

The LM Limiter is used on reciprocating members to protect against work overloads. For instance, if the reciprocating member were to run into a work piece, the impact would dislodge the ball from its ball pocket letting the drive move the block freely along its rail. When a collision occurs, the kinetic energy is instantly converted to shock energy thereby generating a tremendous amount of force. Keep this in mind when selecting a model and use the equation below to determine the amount of adjustment needed.

1. Inertial Force (kgf)

The acceleration characteristic a ($m/sec.^2$) active during linear motions, causes the total weight of the LM limiter without the rail W_1 (kgf) and the weight of the fixture and work piece W_2 (kgf) to act as inertial force F_i (kgf).

$$F_i = \frac{W_1 + W_2}{G} \cdot a \dots \dots \dots (1)$$

When the cam profile establishes the acceleration characteristics.

$$F_i = \frac{W_1 + W_2}{G} \cdot 36Am \frac{P \cdot N^2}{(\theta / m^2)} \dots \dots \dots (2)$$

TABLE

G:	Gravitational speed (m/sec^2)
Am:	Non-dimensional maximum acceleration
P:	Feed pitch (m)
N:	Rotating speed of input shaft (rpm)
θ :	Indexing period (deg)
m:	Number of dwells

2. Workload Force F_w (kgf)

In vertical reciprocating motions, the weight of the limiter and work ($W_1 + W_2$) must be considered as a downward load.

3. Frictional Load Force F_f (kgf)

When moving loads W_3 (kgf) horizontally, we must determine the frictional force F_f (kgf) caused by frictional coefficient μ .

$$F_f = \mu \cdot W_3$$

4. Required Amount of Torque F_t (kgf)

$$F_t = F_i + F_w + F_f$$

5. Tripping Force Adjustment Value F (kgf)

$$F = F_t \cdot C$$

C: Coefficient based on acceleration and deceleration characteristics (normally, C is approximately 2).

APPLICATION EXAMPLE: Sankyo Parts Handler 5GY]

We want to mount a LM Limiter on a vertical moving member to the Sankyo Parts Handler type 5GY to protect the 5GY from accidental collisions while carrying work pieces.

(Requirements)

Stroke I	30 mm
Stroke II	30 mm
Fixture weight	0.6 kgf
Work piece weight	0.3 kgf
Rotating speed of input shaft	60 rpm
Index period	60 deg
Dwells	1
Cam curve	MS (Am = 5.53)

Assuming we choose the 5LM, which can be mounted directly on the 5GY, the weight without the rail portion would be 0.12 kgf.

$$F_i = \frac{0.12 + 0.6 + 0.3}{9.8} \times 36 \times 5.53 \times \frac{0.03 \times 60^2}{60^2} = 0.62 \text{ kgf}$$

$$F_w = 0.12 + 0.6 + 0.3 = 1.02 \text{ kgf}$$

$$F_f = 0$$

$$F_t = 0.62 + 1.02 = 1.64 \text{ kgf}$$

$$F = 1.64 \times 2 = 3.28 \text{ kgf} (C = 2)$$

Accordingly, we should select 5LM-45C.

HANDLING PROCEDURES

1. The holes indicated in the rail diagrams can be used to mount the LM Limiter.
2. Use the tapped holes in the base for mounting attachments. Because the base is made of aluminum alloy, the following tightening torques must not be exceeded.

<u>Bolt</u>	<u>Tightening Torque</u>
M3	70 kgf/cm or less
M4	110 kgf/cm or less
M5	180 kgf/cm or less
M6	260 kgf/cm or less

3. Apply grease (Omega 77 brand or equivalent) according to the following guidelines.

Note: Grease should be applied at least once every month.

- a. Disengage the slide block.
- b. Slide the block all the way to the stopper.
- c. Apply grease to the ball pocket.
- d. Return the block to its original position.

MECHANISM

When an overload occurs, the overload detection pin 1 protrudes by (X) mm providing the means for activating an optional electrical sensor to return error information to the electrical control circuit.

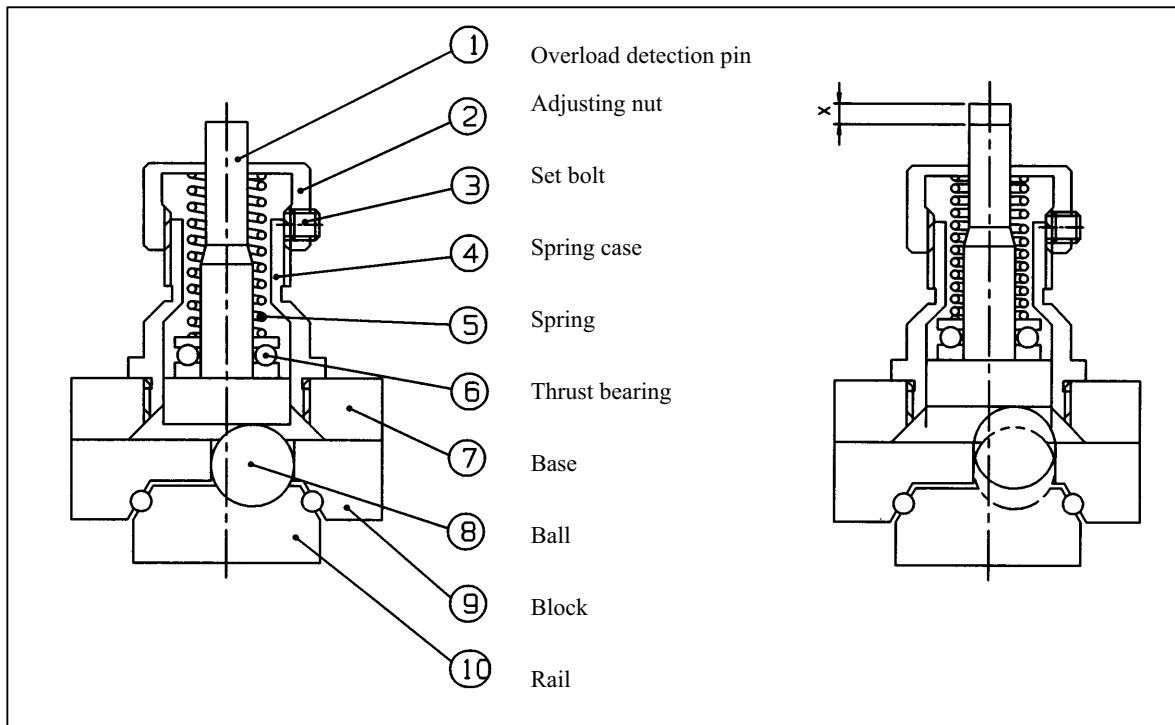

4LM

30 10 18 25 44 19 8
 (2xM4x0.7, 6DP)

3 24 29 10
 2x.50R (installation holes)
 C'BORE Ø0.1A, 4.S.P.

(2xM4x0.7 THRU (installation holes)

Rail installation figure

NOTE: When using the 2-H4 holes, insert the screws from below the rail.

MAX. 17
 43 31 21 12 7.5 34 41 75
 Slide unit

Tripping torque (kgf)

Torque nut adjustment (no. of turns)

Model	Tripping force adjustment range (kgf)	Adjustment nut thread pitch (mm)	Static allowable moment (kgf/m)	Weight (kgf)
4LM-15C	0.5 ~ 1.5	1.0	0.8	0.14
4LM-30C	1.5 ~ 3.0			
4LM-45C	2.6 ~ 4.5			

5LM

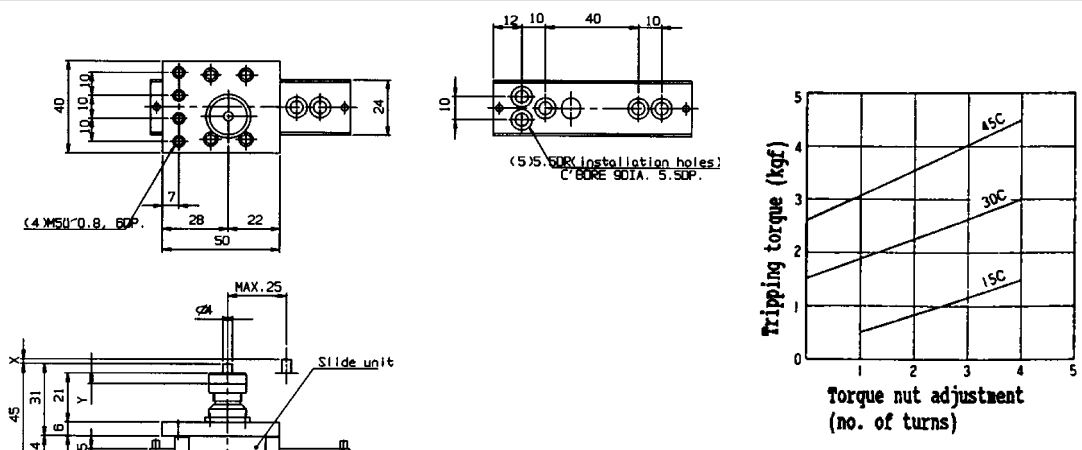

Model	Tripping Force adjustment range (kgf)	Adjustment nut thread pitch (mm)	Static allowable moment (kgf/m)	Weight (kgf)
5LM-15C	0.5 ~ 1.5	1.0	1.6	0.24 0.12kgf
5LM-30C	1.5 ~ 3.0			
5LM-45C	2.6 ~ 4.5			

NOTE: Each model can be changed easily by replacing the springs.

6LM

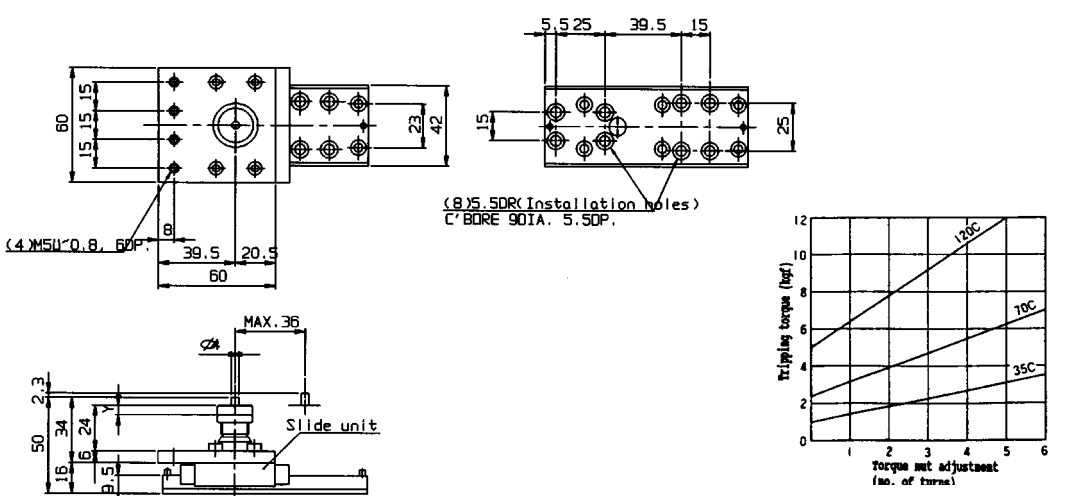

Model	Tripping Force adjustment range (kgf)	Adjustment nut thread pitch (mm)	Static allowable moment (kgf/m)	Weight (kgf)
6LM-15C	1.0 ~ 3.5	1.0	3.2	0.54 0.32kgf
6LM-30C	2.5 ~ 7.0			
6LM-45C	5.0 ~ 12.0			

MOUNTING EXAMPLES

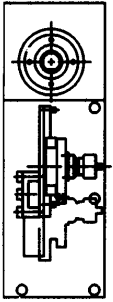

Vertical Mount

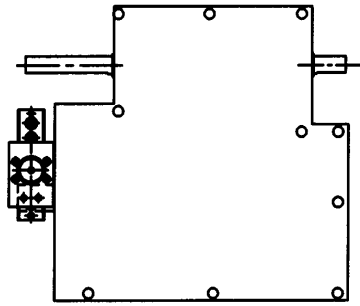

Horizontal Mount

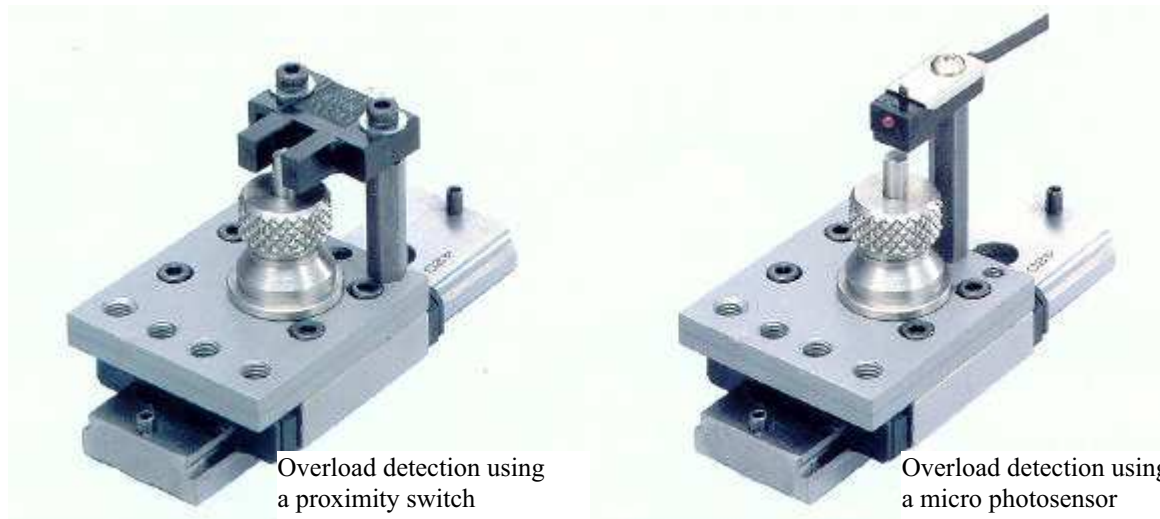

Overload detection using a proximity switch

Overload detection using a micro photosensor

 **SANKYO AMERICA, INC.**

SANKYO TORQUE LIMITERS LINEAR MOTION TYPE

1. Sankyo's LM Limiters are a compact solution for protection against linear motions. The mechanism consists of a slide unit and ball and ball pocket arrangement.
2. The holes indicated in the rail diagrams can be used to mount the LM Limiter.
3. Use the tapped holes in the base for mounting attachments. Because the base is made of aluminum alloy, the following tightening torques must not be exceeded.

<u>Bolt</u>	<u>Tightening Torque</u>
M3	70 kgf/cm or less
M4	110 kgf/cm or less
M5	180 kgf/cm or less
M6	260 kgf/cm or less

4. Apply grease (Omega 77 brand or equivalent) according to the following guidelines.
 Note: Grease should be applied at least once every month.
 - a. Disengage the slide block.
 - b. Slide the block all the way to the stopper.
 - c. Apply grease to the ball pocket.
 - d. Return the block to its original position

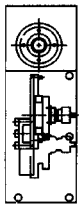

Vertical Mount

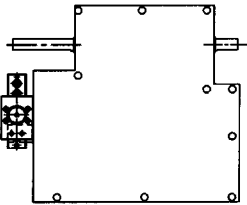

Horizontal Mount

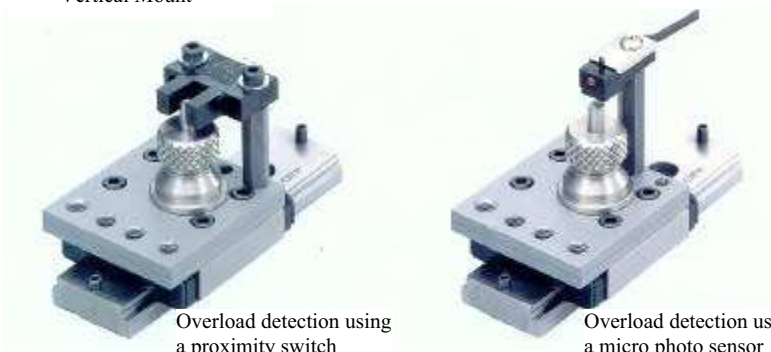
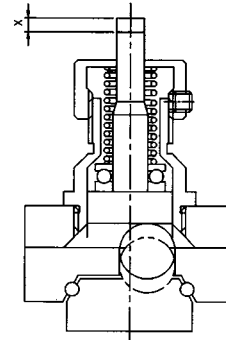
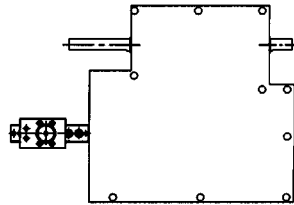

SANKYO AMERICA, INC.

P.O. Box 4338 • 10655 St. Rt. 47 • Sidney, Ohio 45365 U.S.A.
 Phone 937-498-4901 • Fax 937-498-9403

SANKYO Torque Limiter Instruction Manual TAD series

Thank you for purchasing a SANKYO Torque Limiter. These instructions contain important information on the installation and adjustment of a SANKYO Torque Limiter. Read carefully to obtain optimum performance of this product. This instruction manual should be maintained in a safe place and made readily available for future reference.

1. Description of TAD series

Sankyo's torque limiters are reliable overload protection devices equipped a torque shutting down mechanism. It is therefore that Sankyo's torque limiter features highly accurate shutting torque and easy-to-adjust torque setting.

Sankyo developed TAD series as an overload protection device particularly for output shaft of Sankyo's TAD series, an indexing drive equipped a reducer and a motor in one house. Before using the torque limiter, please refer to the table of specifications shown at catalog to make sure that actual usage is in allowance value.

[Legend Plate]

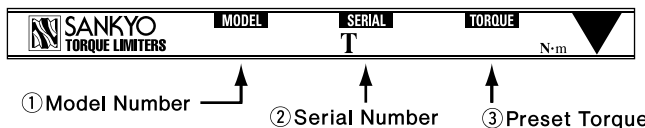

[Structure]

Figure 1

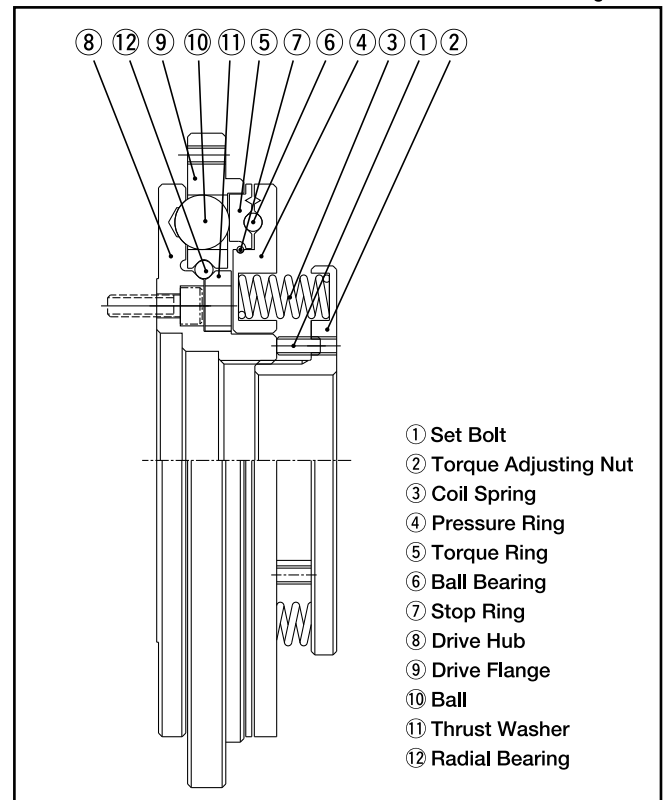

2. Types

Model	T (N·m)	Ym	X	P	a	b	c	Nm	W
7TAD - 15L - 25H	40~150 100~250	5	3	2	2450	2950	45	200	4.5
9TAD - 20L - 45H	60~200 140~450	7	3.5	2	5200	5000	100	200	9.6
11TAD - 23L - 60H	90~230 150~600	7.5	3.7	2	7300	7000	180	200	15
15TAD - 100L - 220H	300~1000 650~2200	7	5.5	2	11800	12000	430	140	43
23TAD - 350L - 550H	1200~3500 2000~5500	8	6.5	2	24800	35000	1950	100	110

⚠ WARNING

All SANKYO Torque Limiters are individually assembled and adjusted to meet specific standards. Even though a part may be common across different models they should not be interchanged; i.e., bearings.

- T : Adjusting range for tripping torque
- Ym : Maximum tightening length (mm)
- X : Movement of detection panel when overloading (mm)
- P : Thread pitch on torque adjusting nut (mm)
- a : Maximum allowable radial load (N)
- b : Maximum allowable thrust load (N)
- c : Maximum allowable bending moment (N·m)
- Nm : Maximum allowable rotating speed (rpm)
- W : Weight (kg)

⚠ CAUTION

Tightening more than Ym, maximum tightening length might be a cause of improper functioning of the Torque Limiter.

[Relation between tripping torque and spring deflection]

When allowable torque is adjusted, please refer these graphs to find the amount of spring deflection. Number of rotation for the pressure nut can be roughly estimated by dividing the amount of the spring deflection by P, thread pitch.

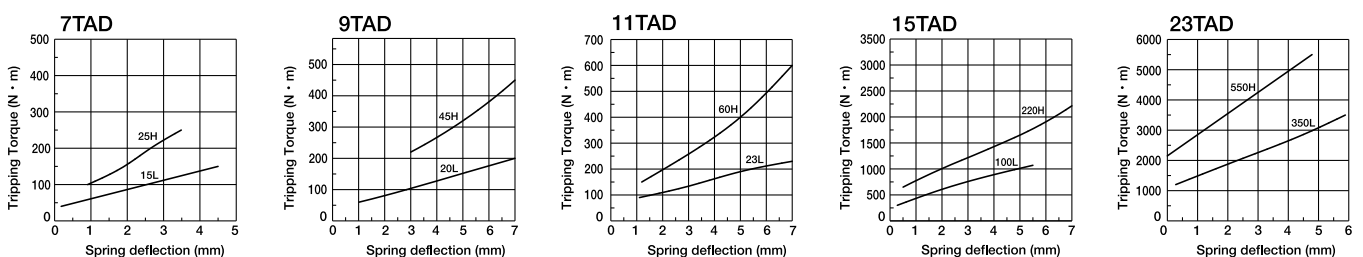

3. Torque allowance adjustment

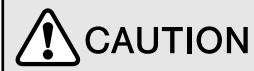

Adjustment of the allowable torque must be performed. Even the allowable torque was preset, it must be confirmed. After adjustment of the torque, ①, set bolt must be tightened to prevent the loosening.

The allowable torque is easily adjusted by a turn of the torque adjusting nut ②. However, due to the nature of the setting, the amount of torque allowance cannot be indicated in real terms. Refer to Figure 1 to determine the proper amount to tighten. For a more accurate adjustment, use an instrument such as a torque gauge or spring scale.

<Memo at Legend Plate>

The tripping torque will be stamped on the legend plate only if the required allowable torque was known when the order was received. If the tripping torque on the legend plate is blank, the allowable torque is not adjusted and ①, set bolt is not tightened, so that required procedure to adjust the allowable torque must be performed, and then tightened ①, set bolt. Once, the tripping torque is adjusted or changed, it is recommended to write the value of the torque on the legend plate with a marker pen.

4. Installation and Center Align



Bolts for installation and bolts for fixing the thrust washer ⑪ are located same pitch circle. When trying to move this product, DO NOT loosen bolts for fixing the thrust washer ⑪. Bolts for installation are bigger than bolts for fixing and they are buried deeply.

- 1) Make sure that installing surfaces of spigot part A of the torque limiter, drive hub ⑧, and drive flange ⑨ have no scratch or burr.
- 2) Loose set bolts ①. Remove torque adjusting nut ②, 8 pieces of coil spring ③. Then remove pressure ring ④, which includes torque plate ⑤, ball bearing ⑥, and stop ring ⑦. Installation holes will be observed. At this moment, please DO NOT loosen the bolts for fixing thrust washer ⑪. Loosening the bolts for fixing will cause of improper function of the torque limiter. The grease has been already applied, so dust must be kept away from it.
- 3) Establish spigot part A as a base. Place the unit (a series), and temporarily fix with bolts.
- 4) Set the dial gauge as it touches the surface of drive flange ⑨, measure run-out B. Set the gauge at spigot of flange circular surface, and measure run-out (C). While adjusting the unit as both values of run-out (B) and (C) are within allowance values shown below, fix the unit at final position by tightening the bolts. (See Figure 3.)
Run-out at edge (B) >0.02mm T.I.R. Radial run-out (C) >0.02mm T.I.R.
- 5) Install the parts, which were removed at 2). Fasten the torque adjusting nut ②. Set the torque at same time.
- 6) After setting the torque, set bolt ① must be tightened.
- 7) In case of installing a table or other equipment on the flange surface of torque limiter, concentricity must be checked and adjusted. Use dial gauge to measure at (D). Adjust the radial run-out if it is needed.

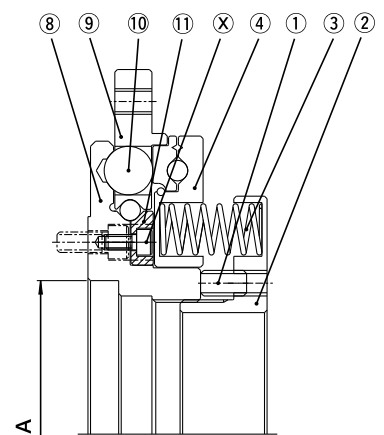

Figure 2

※1 The initial alignment is crucial to the performance and life of the torque limiter.

※2 When mounting a table on the flange, make sure the center of the table is concentric with the flange. Failure to do so will result in poor indexing accuracy.

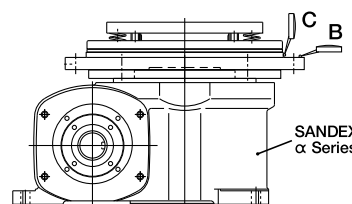

Figure 3

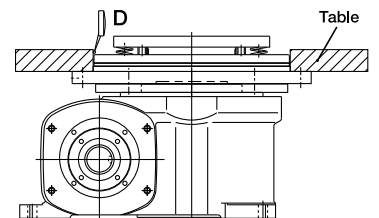

Figure 4

5. Maintenance

Grease must be applied regularly. every 1000-2000 hours.

Remove torque adjusting nut ② and pressure ring ④ from main unit after loosening set bolt ①. After removing them, 9 balls can be observed. Apply the recommended grease listed the below table. Reassemble the unit by following reversed procedures. When applying the grease on ball bearing ⑫, use the greasing hole to put in the grease. It is recommended to apply the grease at ⑶ and ball bearing ⑫ together.

Note, always use a lithium type grease (density grede 2).

[Recommended greases]

Nisseki	Multinotch Grease 2, Epinotch Grease AP2, ★New Molinotch Grease 2
Idemitsu	Daphone Eponex Grease 2 (EP2), ★Daphone Molybdenum Grease 2
Kyoseki	Risonich Grease No.2, Risonich Grease EP-2
Mitsubishi	Multi-Purpose Grease No.2, ★Multi-Purpose M Grease No.2
Esso	Beacon 2, ★Beacon Q2, Lystan 2, Lystan EP-2
Mobil	Mobilax 2 (EP2)

★contains molybdenum disulfide

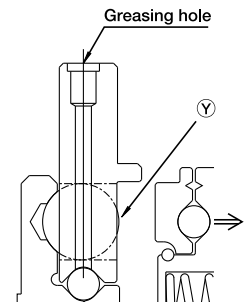

Figure 5



■Miyagi PHONE.0228(23)5111
■Shizuoka PHONE.0537(36)2233
■Osaka PHONE.06(6253)1911

■Tokyo PHONE.03(3800)3330
■Nagoya PHONE.052(265)0577
■Okayama PHONE.086(231)1188



•

TC-Type

Size	4TC	5TC	6TC	7TC	8TC	11TC	14TC	18TC
Range of Tripping Torque (N-m)	0.3-4.5	0.8~18	2~28	20~350	40~450	70~1000	100~2000	700~5000
Permissible Revolutions per Minute (rpm)	2000	1600	1000	700	500	400	300	200

TC series Specifications

Item	Unit	4TC	5TC	6TC	7TC	8TC	11TC	14TC	18TC
Adjusting range for tripping torque	N-m	0.3~4.5	0.8~18.0	2~50	20~350	40~450	70~1000	100~2000	700~5000
Thread pitch on torque adjusting nut	mm	1	1.5	1.5	2	2	2	2	2
Maximum allowable angle of deviation error	deg	1	1	1.5	1.2	1.2	1	1	0.5

Maximum allowable clearance error•	mm•	±1.0•	±1.0•	±1.5•	±1.8•	±2.0•	±2.5•		
Maximum allowable parallelism error•	mm•	0.05•	0.05•	0.05•	0.1•	0.1•	0.1•		
Maximum allowable rotating speed•	r.p.m.•	2000•	1600•	1000•	700•	500•	400•		
Inertia moment of torque limiter•	Kg-m ² •	0.9×10 ⁻⁴ •	4.0×10 ⁻⁴ •	1.7×10 ⁻³ •	5.8×10 ⁻³ •	1.4×10 ⁻² •	3.5×10 ⁻² •	9.3	
Weight•	kg•	0.25•	0.68•	1.5•	3.2•	5.3•	10.8•		
Pre-machined shaft holes (Hole size)•	A•	mm•	10~15•	12~22•	15~30•	20~40•	30~50•	40~60•	50
	B•	mm•	-•	15~20•	15~25•	20~35•	30~50•	40~60•	50
	C•	mm•	-•	-•	16~25•	20~35•	30~45•	35~60•	50
	D•	mm•	-•	-•	-•	-•	-•	-•	
	E•	mm•	-•	-•	-•	-•	-•	-•	
	F•	mm•	-•	-•	16~22•	20~35•	30~45•	35~60•	50

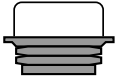

4TC

SANDEX

4TC Dimension

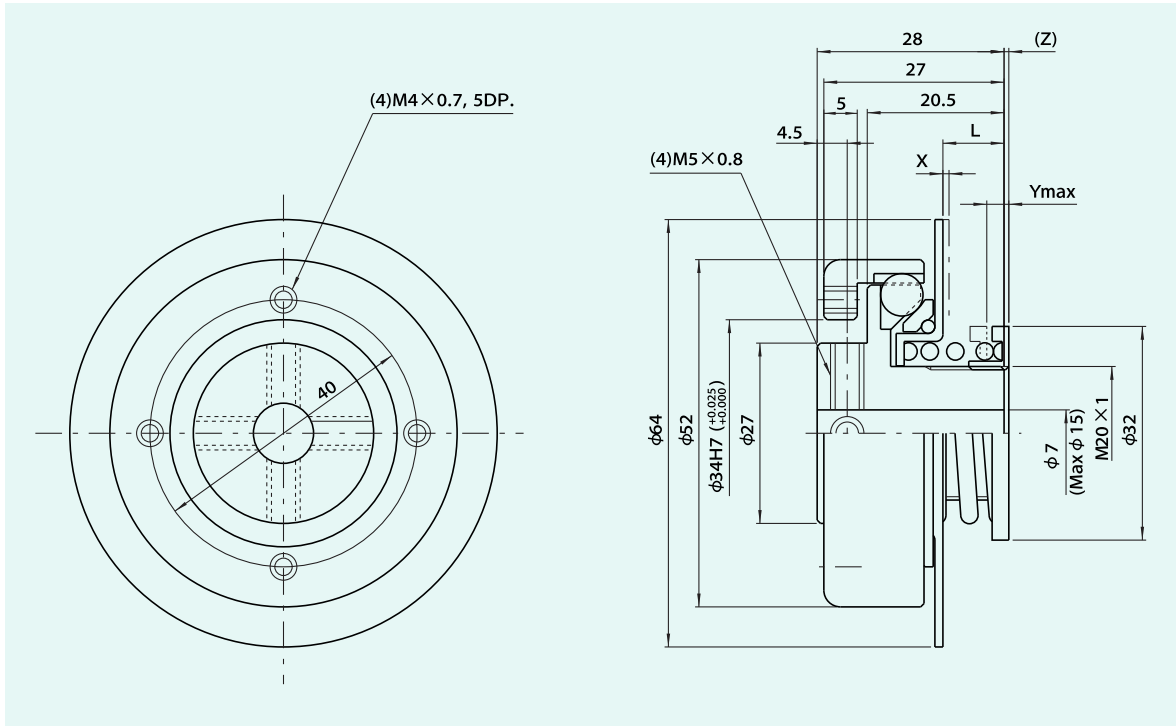



5TC

SANDEX

5TC Dimension

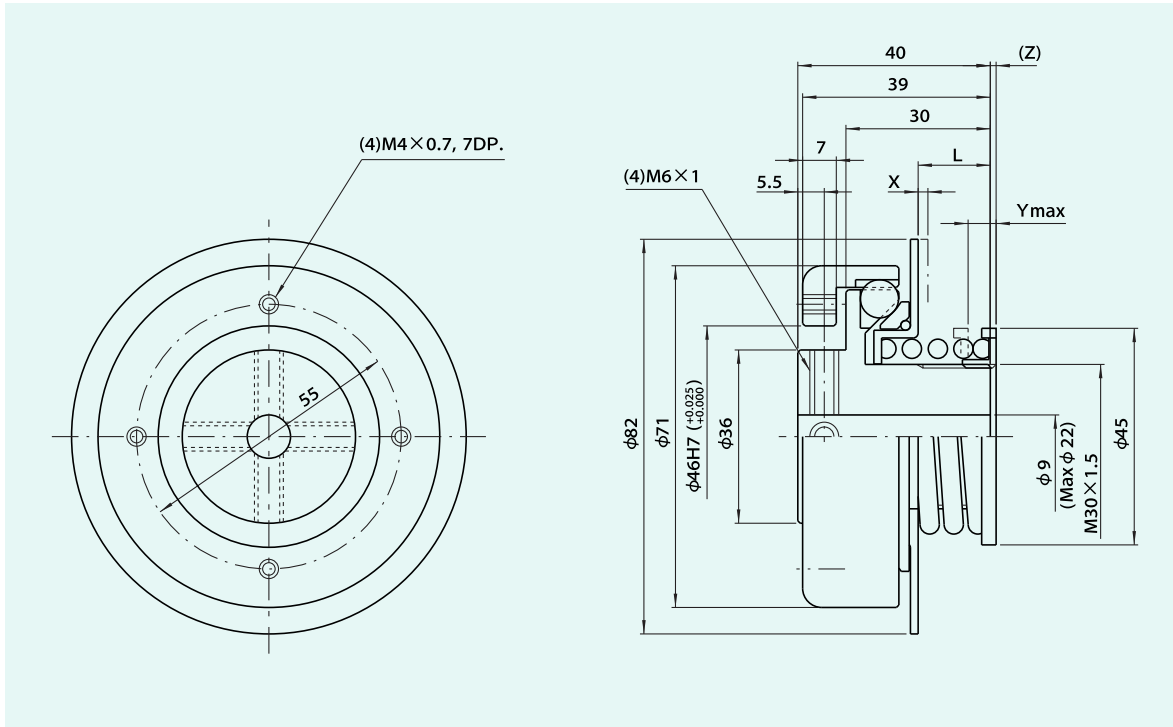



6TC

SANDEX

6TC Dimension

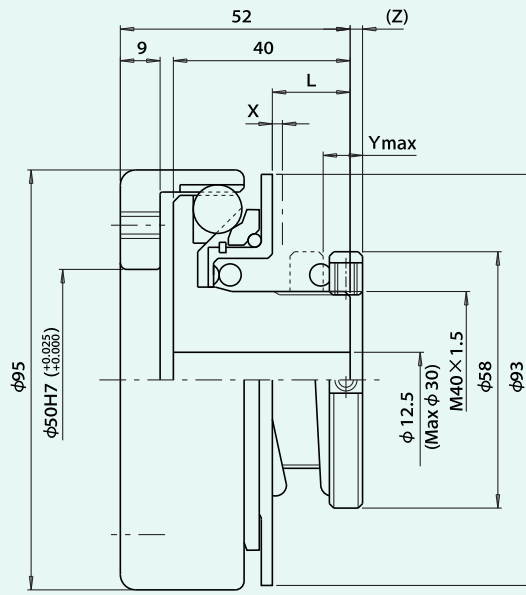
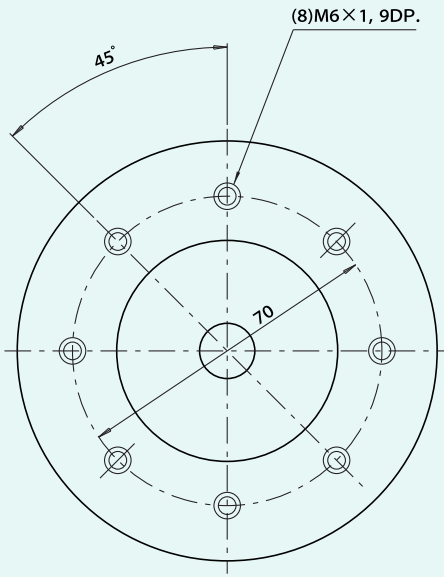



7TC

SANDEX

7TC Dimension

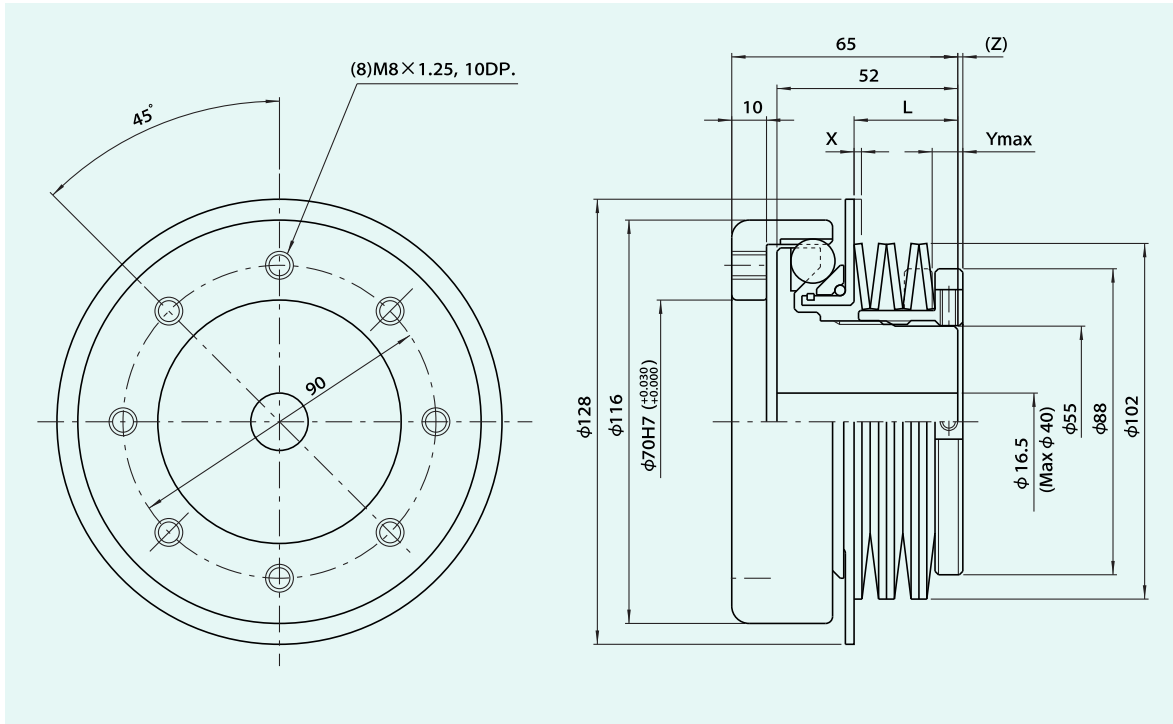



8TC

SANDEX

8TC Dimension

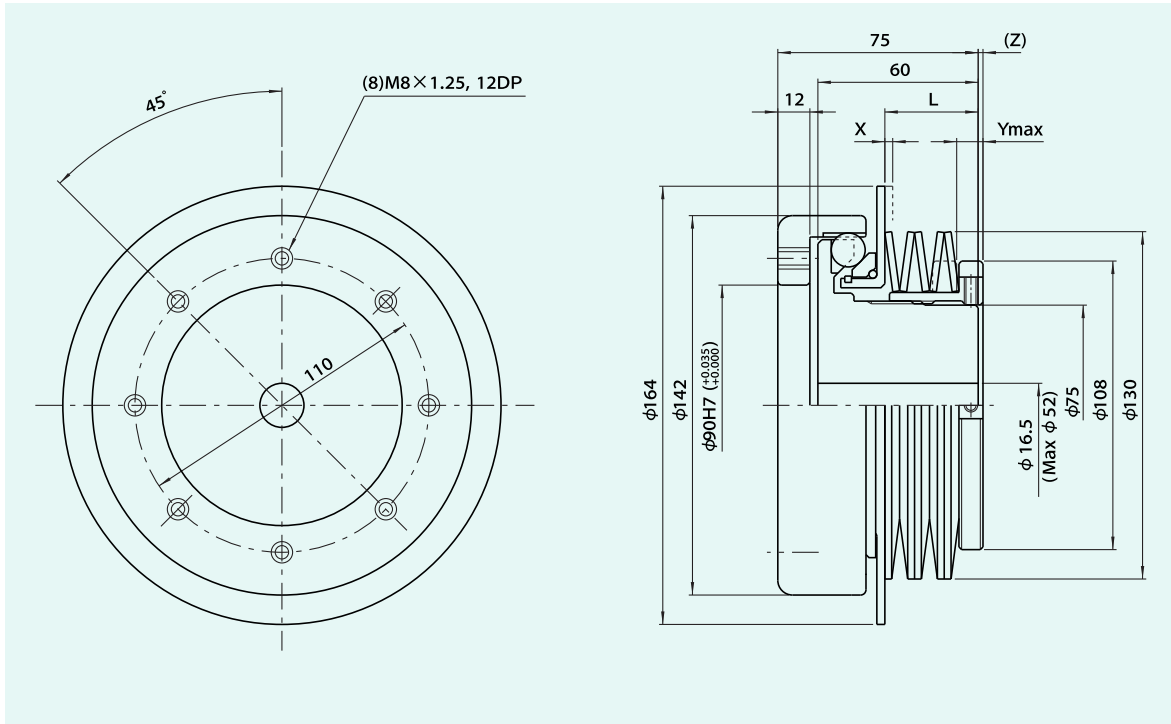



11TC

SANDEX

11TC Dimension

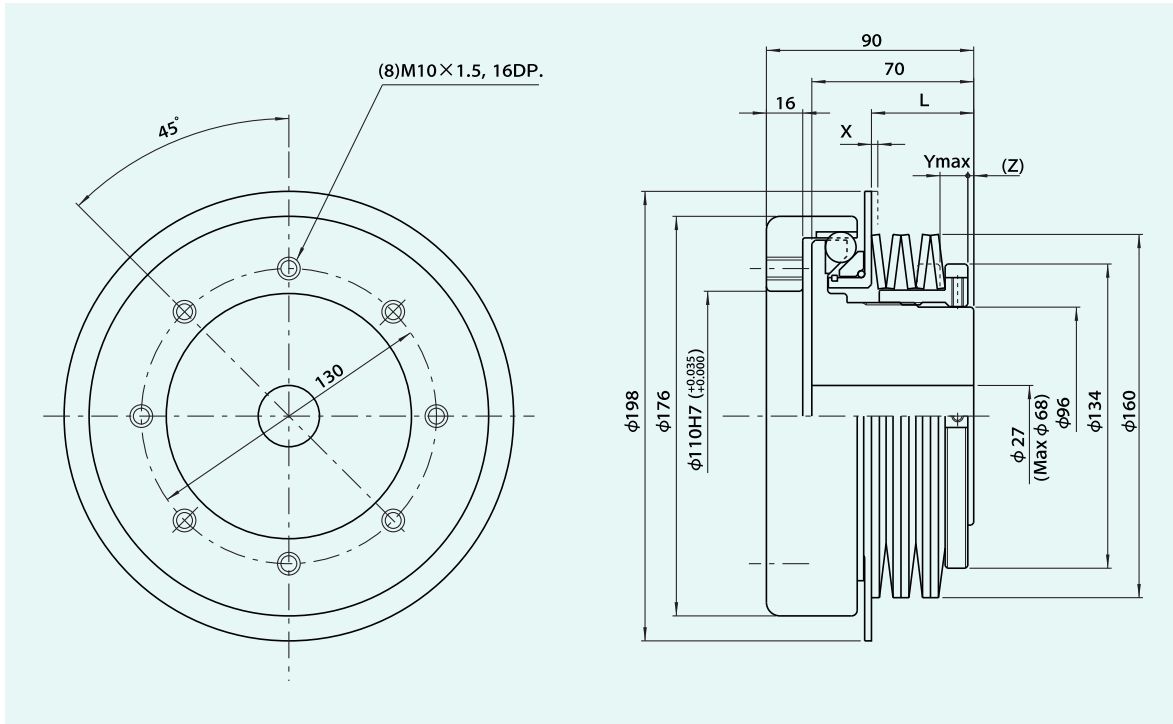



14TC

SANDEX

14TC Dimension

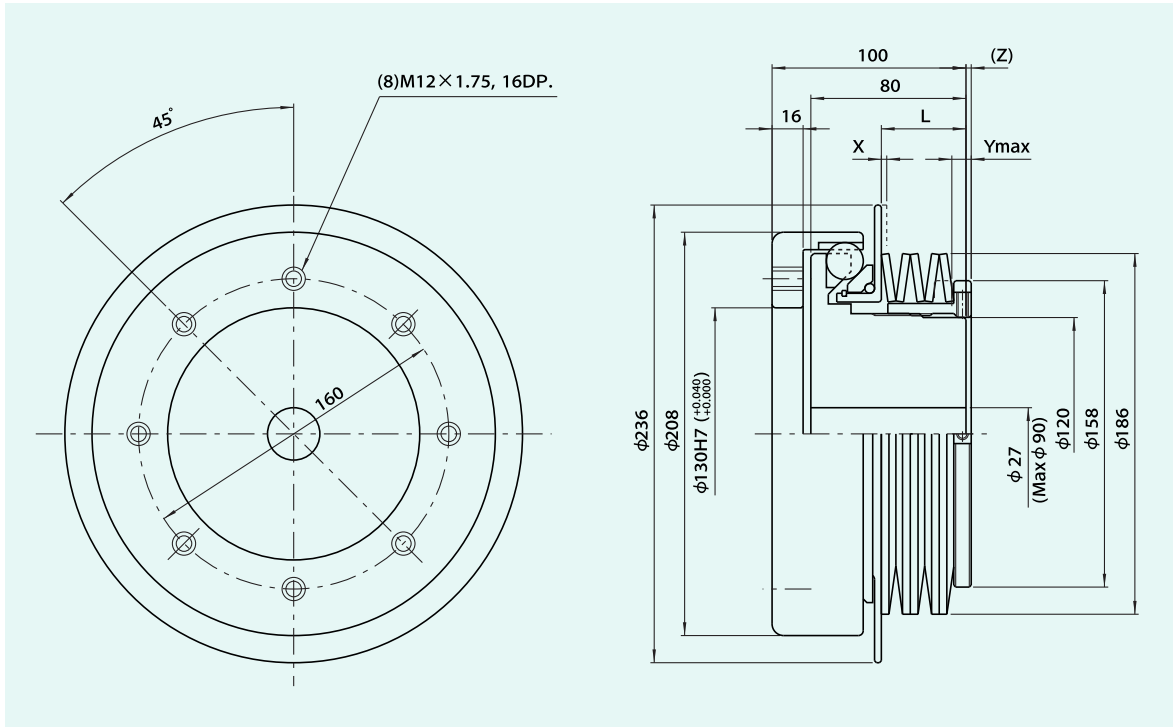



18TC

SANDEX

18TC Dimension

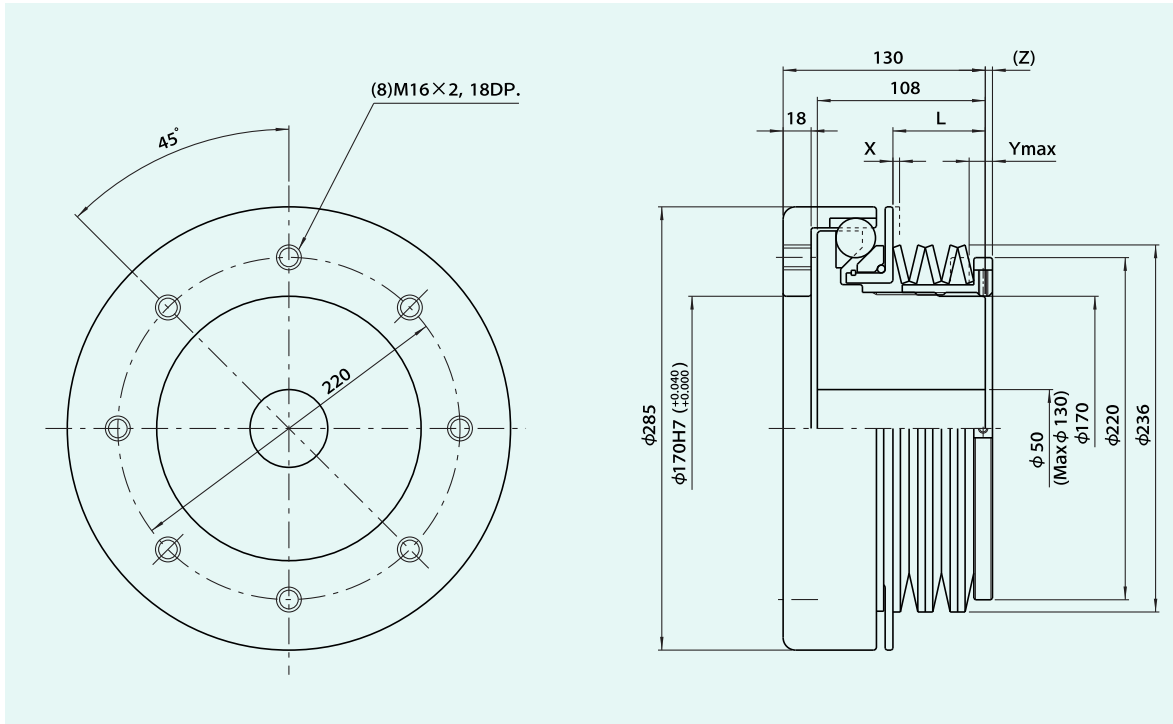



•

TF-Type

Size	4TF	5TF	6TF	7TF	8TF	11TF	14TF	18TF
Range of Tripping Torque N m	0.3 4.5	0.8 18	2 50	22 400	50 600	80 1200	110 1800	400 5000
Permissible Revolutions per Minute rpm	2000	1600	800	600	400	300	250	180

TF series Specifications.

Item	Unit	4TF	5TF	6TF	7TF	8TF	11TF	14TF	
Adjusting range for tripping torque	N-m	0.3~4.5	0.8~18.0	2~50	22~400	50~600	80~1200	110~	
Thread pitch on torque adjusting nut	mm	1	1.5	1.5	2	2	2		
Maximum allowable radial load	N	69	108	3822	7154	10290	14700	23000	
Maximum allowable thrust load	N	392	569	7938	10780	14700	22050	28000	
Maximum allowable bending moment	N-m	3.4	6.9	118	196	372	666	1000	
Maximum allowable rotating speed	r.p.m.	2000	1600	800	600	400	300	200	
Inertia moment of torque limiter	Kg-m ²	0.5×10 ⁻⁴	2.4×10 ⁻⁴	1.3×10 ⁻³	4.8×10 ⁻³	1.5×10 ⁻²	3.5×10 ⁻²	8.5×10 ⁻²	
Weight	kg	0.24	0.50	1.5	3.4	6.2	11.4	20	
Pre-machined shaft holes (Hole size)	A	mm	10~12	12~20	15~30	20~40	30~50	40~60	50
	B	mm	-	14~17	15~25	20~35	30~50	40~60	50
	C	mm	-	12~16	16~25	20~35	30~45	35~60	50
	D	mm	-	-	16~25	20~35	30~45	35~60	50
	E	mm	-	-	16~20	20~30	30~40	35~55	50
	F	mm	-	-	16~22	20~35	30~45	35~60	50



4TF Dimension

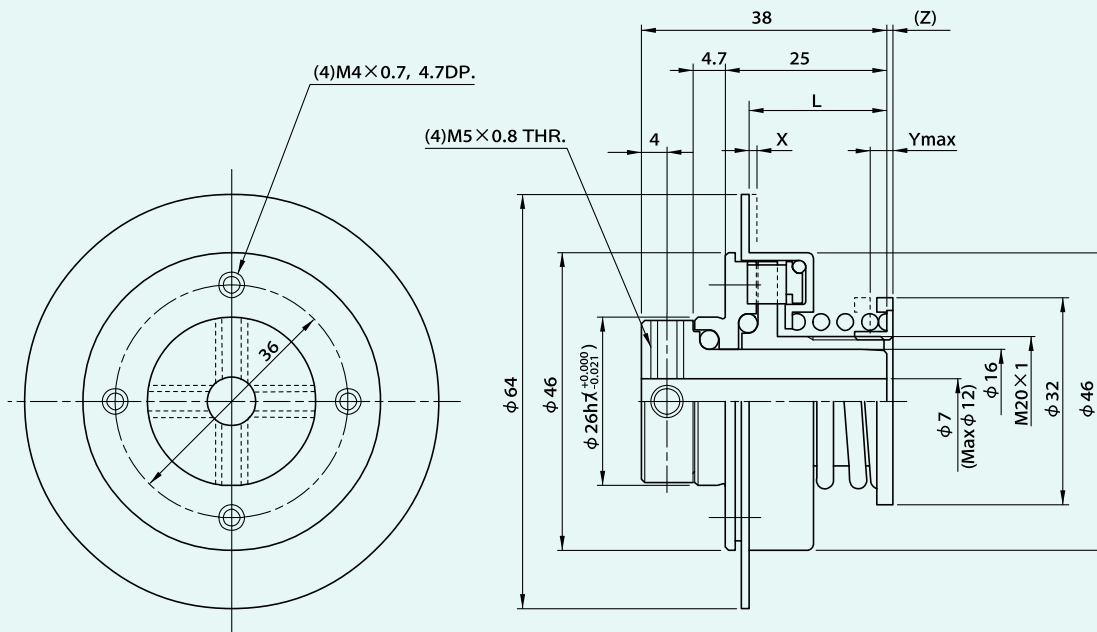



5TF

SANDEX

5TF Dimension

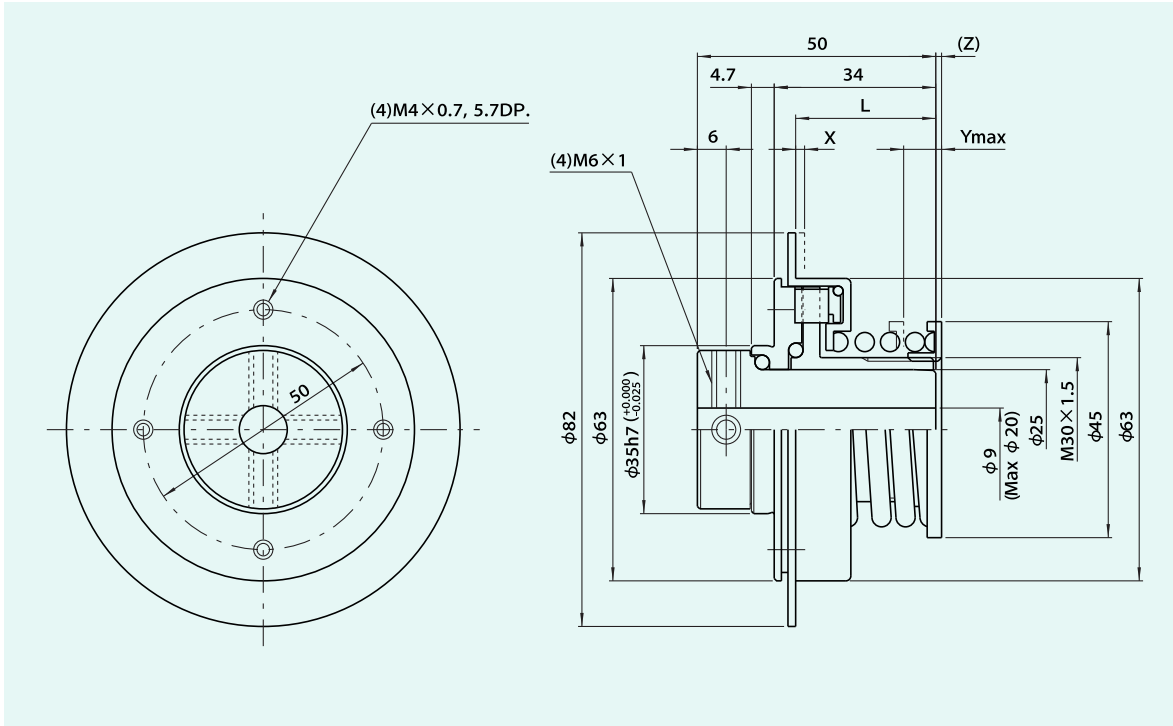

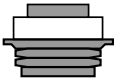

6TF

SANDEX

6TF Dimension

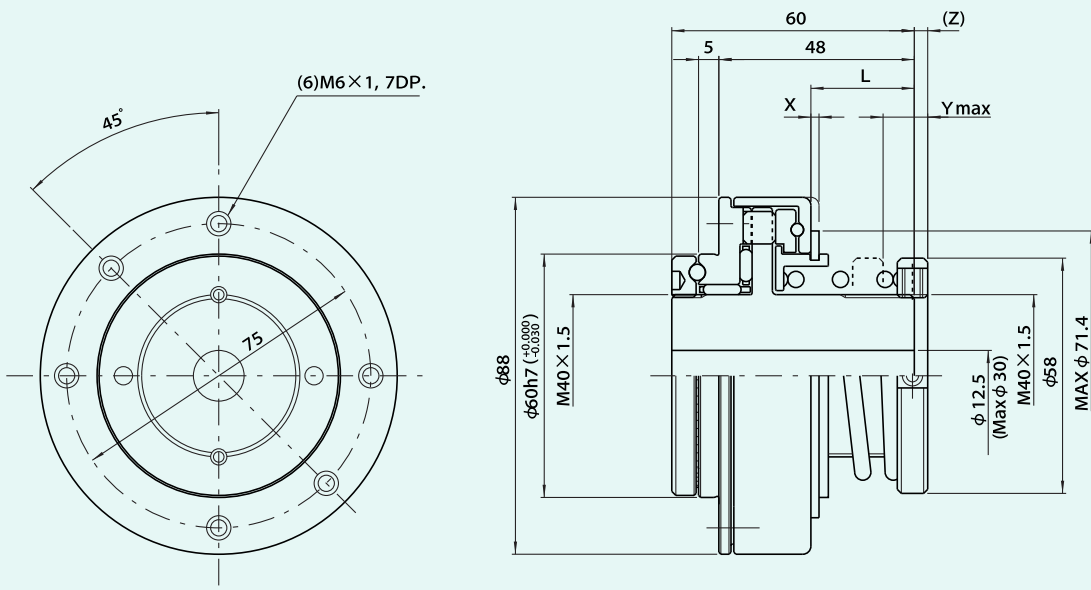

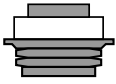

7TF

SANDEX

7TF Dimension

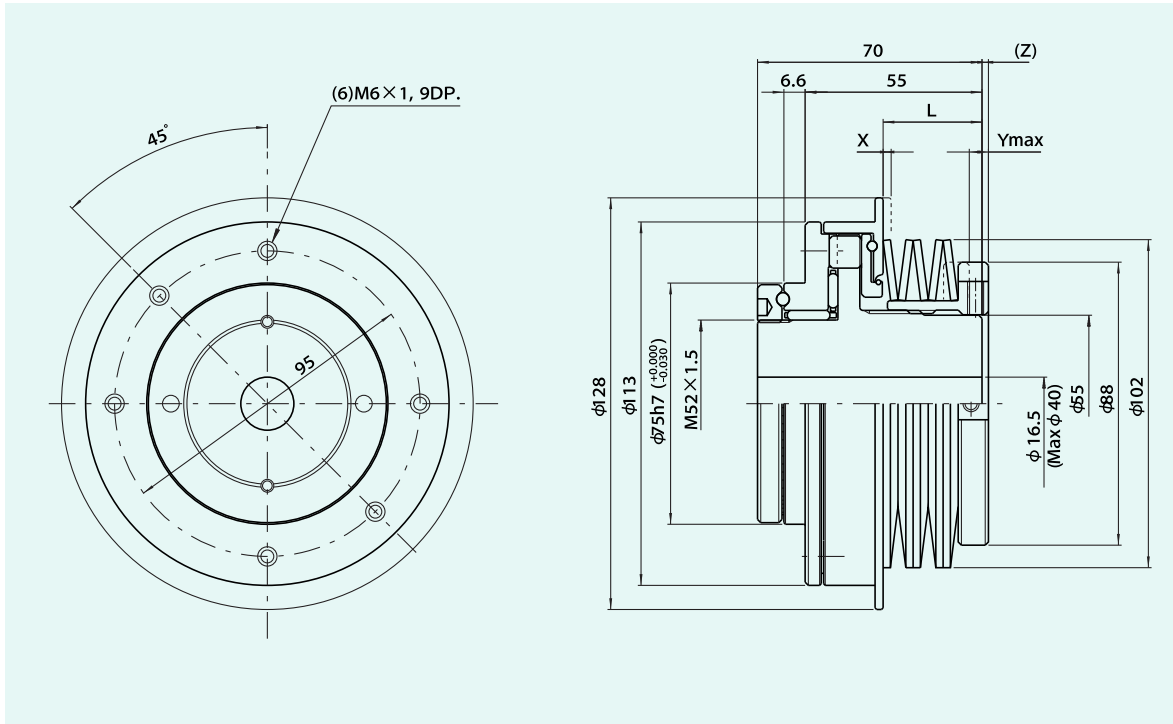

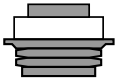

8TF

SANDEX

8TF Dimension

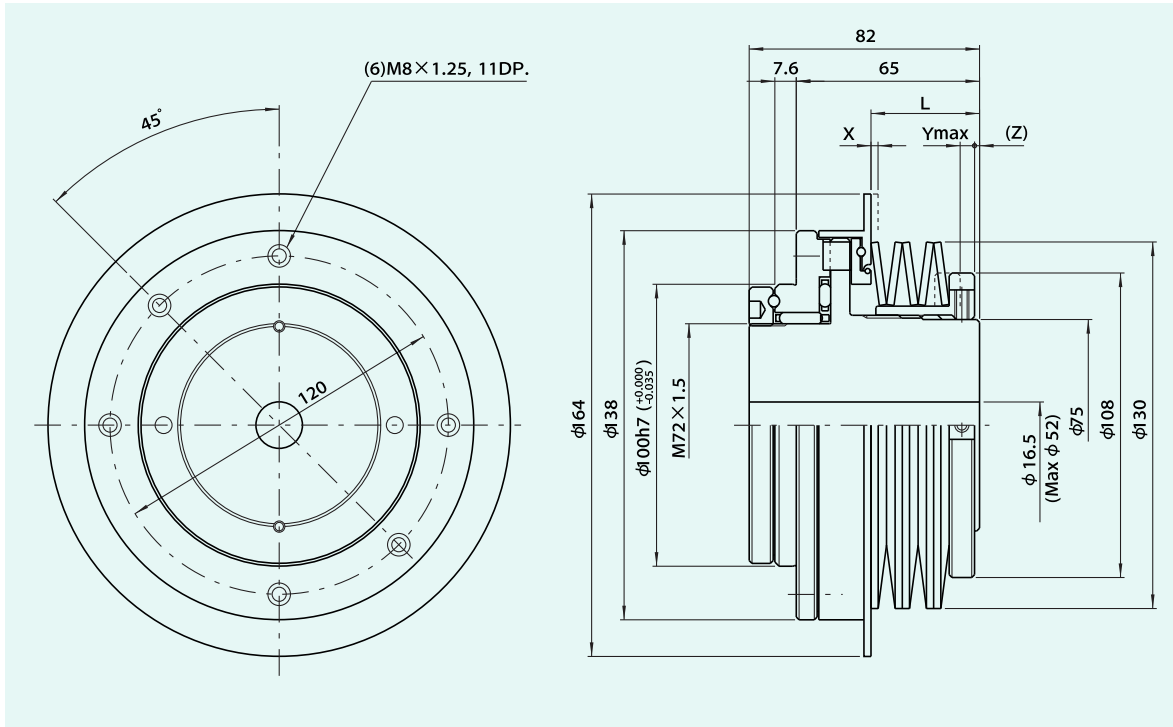

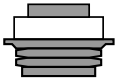

11TF

SANDEX

11TF Dimension

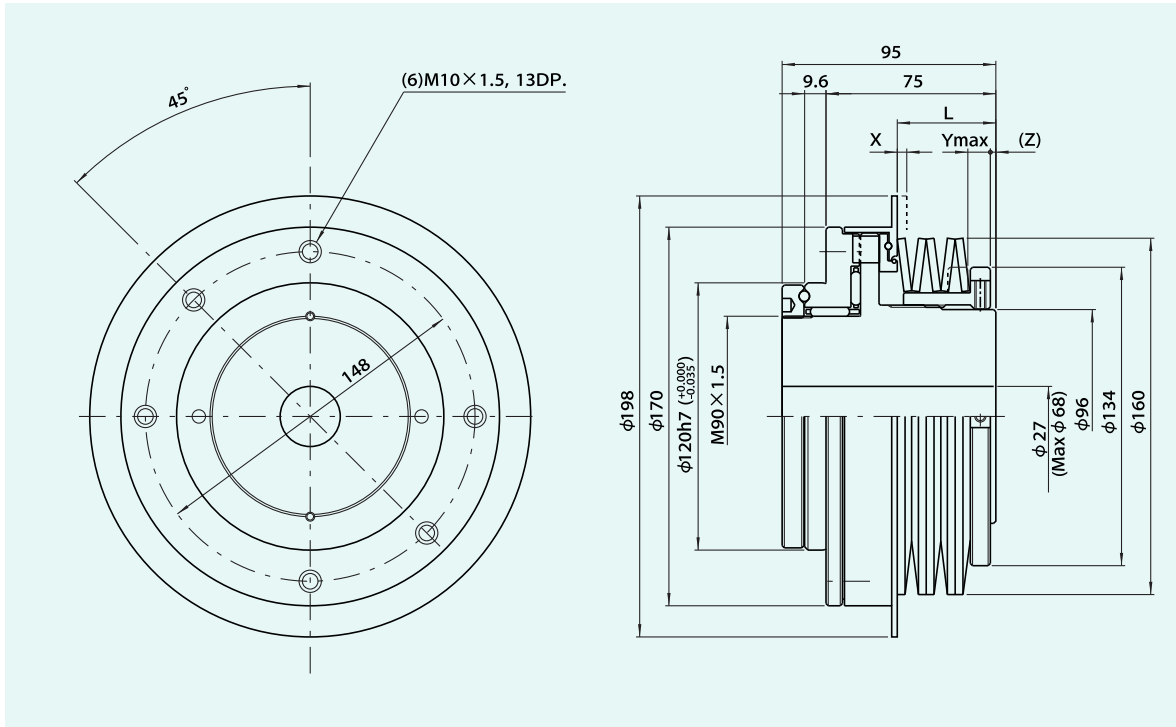

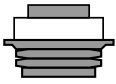

14TF

SANDEX

14TF Dimension

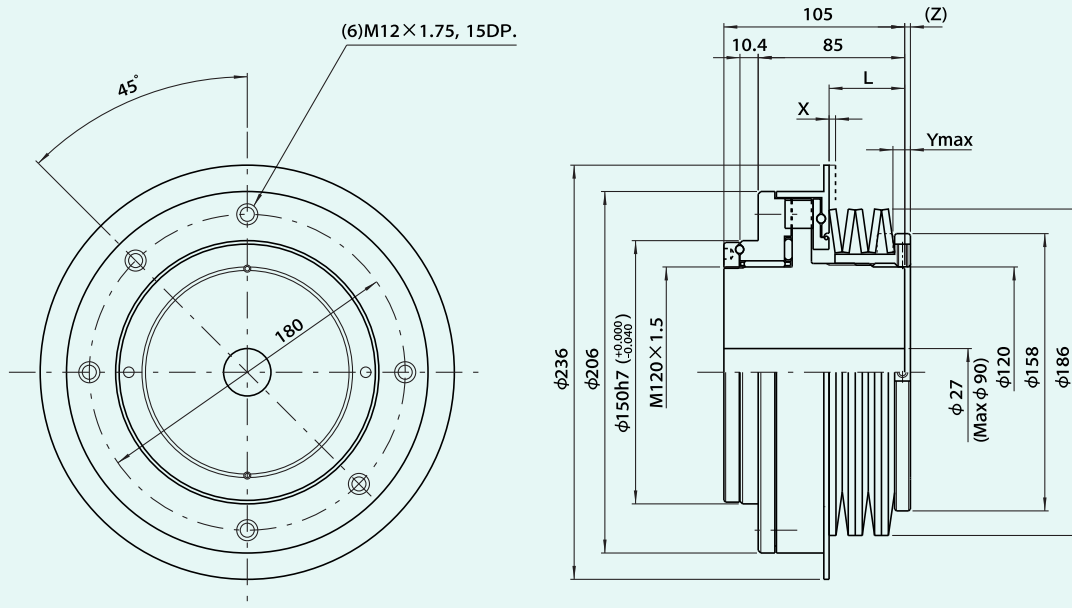

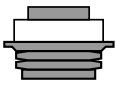

18TF Dimension

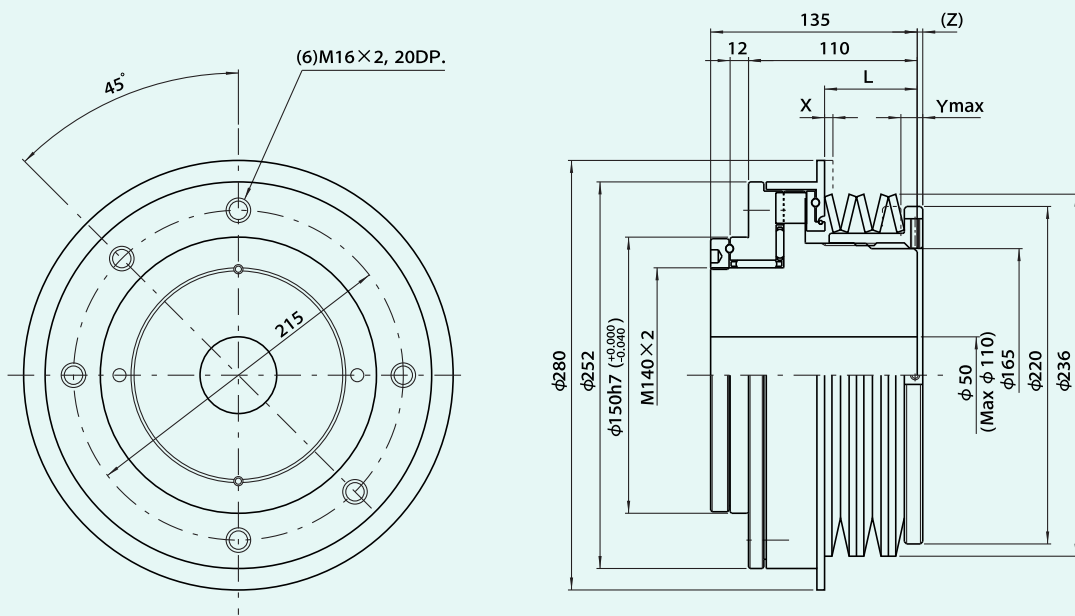

Sankyo - Torque Limiters